

The QMM Mk10 - From an idea of N.Camus design by JL Naudin

The Reed'motor, courtesy of Nelson Camus

created on 02/26/98 - *JLN Labs* - last update on 03/27/98

This motor is based on the diagram below, courtesy of Nelson Camus. :

"This motor is able to run by itself and give FreeNRG from the magnets when the aluminium sheets are removed from the blocking position (between the magnets). After they are removed, the motor starts itself without stopping, like a real perpetual motion motor. The coils 1,2,3,4 are used only for tapping the magnetic energy and convert it into useable electrical power....."

The Reed's motor is a North pole magnetic motor. To start the motor, it is necessary to move a little disc (at the top) with your finger. Two brackets mounted in cross with four aluminum sheets pass between the North poles on the top and the bottom of the cylinder. When you turn the little disc with your finger, the two brackets in cross leave the gap between the magnets.

- When you insert the aluminum sheets mounted on the brackets between the magnets with the same polarisation North, you STOP the motor.
- When you turn the little disc clockwise, you START the motor.

This motor is **a real perpetual motion motor.**

The only power that you require is the power needed for turning the little disc with your fingers during the startup. If you want more power, you need to use NIB magnets for a bigger magnetic flux, so you can get more power."

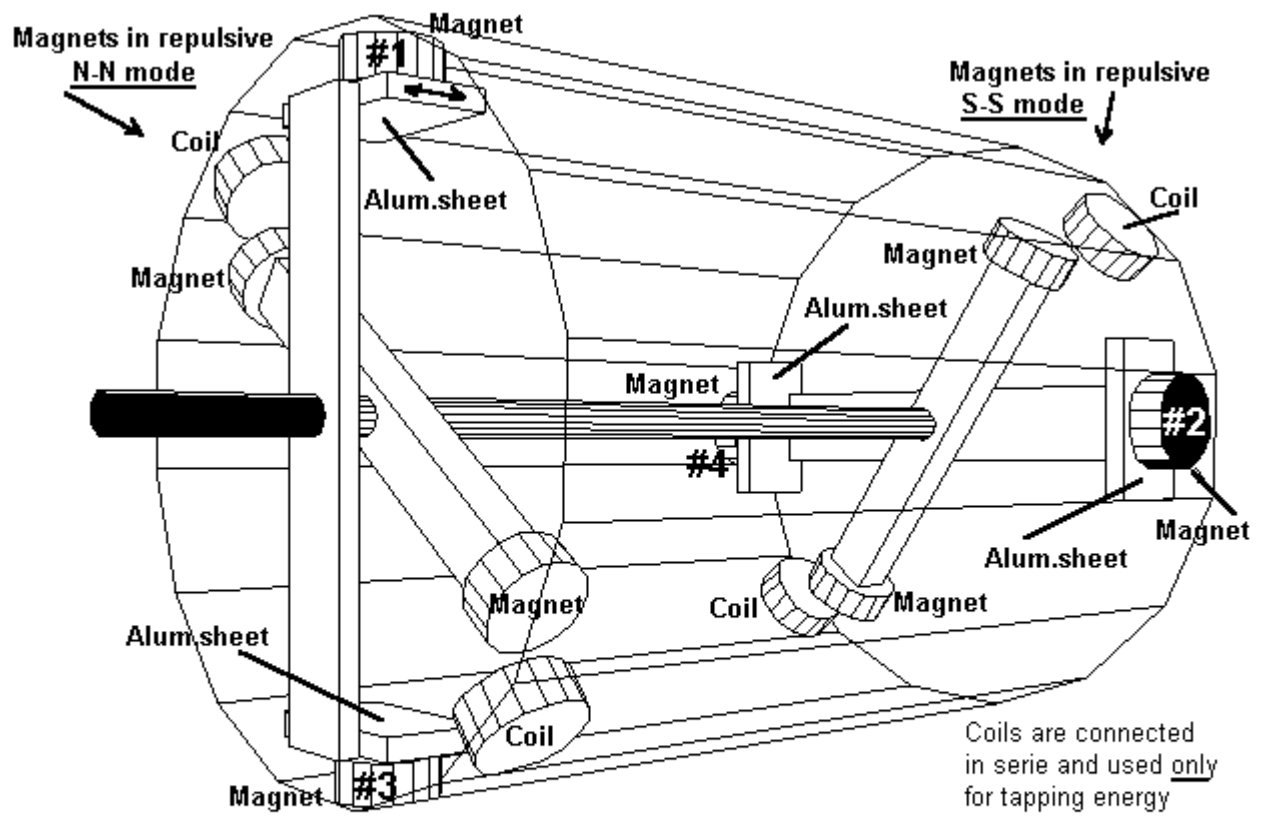

The Reed's Motor by Nelson Camus
Design and Drawing Jean-Louis Naudin
 26 February 1998 - Email: JNaudin509@aol.com

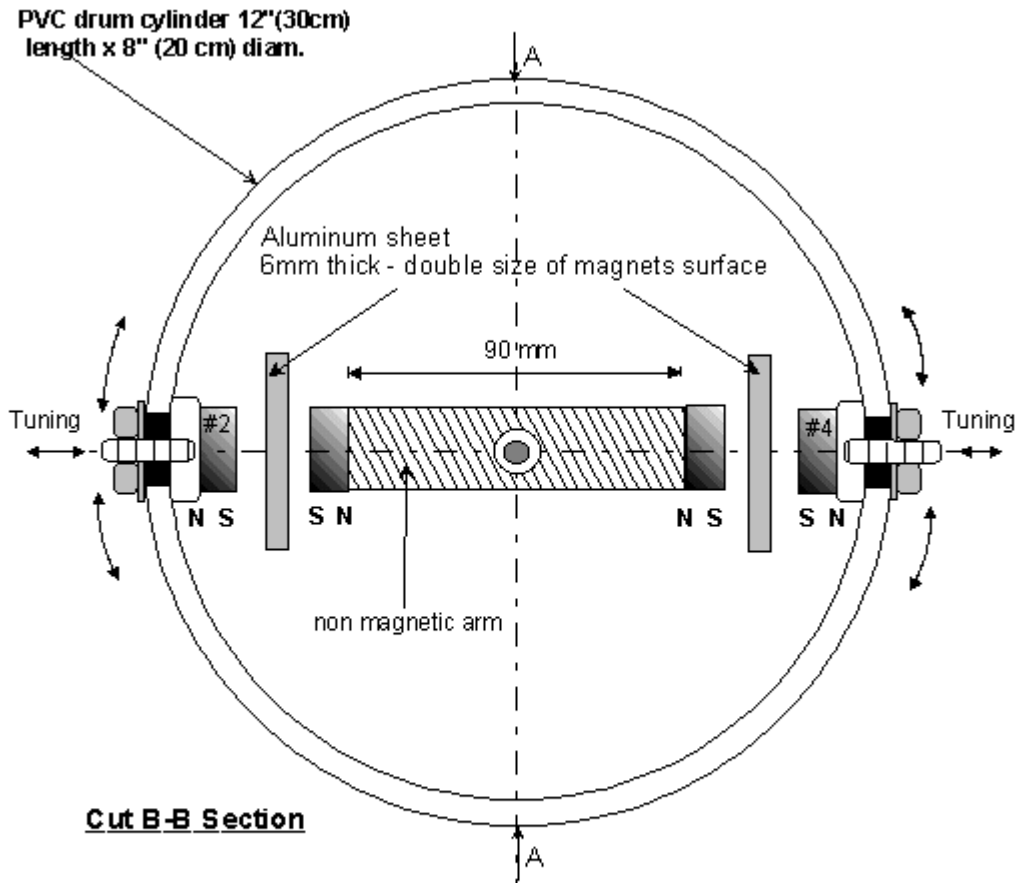

Cut B-B Section

The Reed's Motor by Nelson Camus
 Design and Drawing Jean-Louis Naudin
 26 February 1998 - Email: JNaudin509@aol.com

Preliminary Adjustments :

1 - With the Aluminum sheets out, spin the rotor with your finger clockwise, insert the magnet #1, then #2, the rotation will jump. In the first jump insert the magnet #3 and #4 quickly.

The motor will still spinning.

2 - The magnets #1, #2, #3, #4 require to be far of the rotor magnets. Using an screwdriver adjust the #1 down 1/2 turn in the bolt, follow with the #2, #3, #4, you will have more speed.

NOTE: if one of the outside magnets has more repulsion than the next one, the motor will stop. **Take care.**

3 - When the motor is in rotation you can stop it using the Aluminum sheets. Also you can decrease the RPM with the same procedure.

4- The magnets #2 and #4 require to be no in 90 degrees -85 to 89 degrees adjustable the elevation and azimuth.

If the motor stop or no rotate the azimuth and elevation of #2, #4 are notin the correct angle.

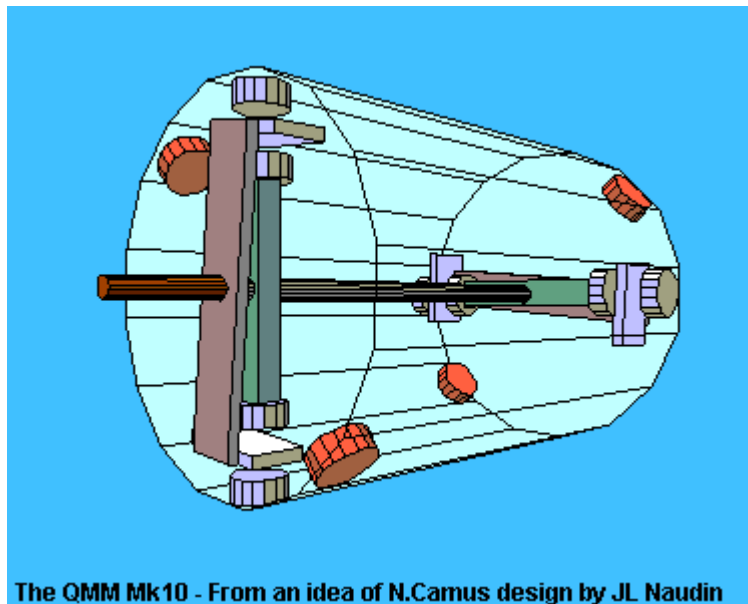

Additional comments from Nelson Camus :

- **"You don't need electric pulses to run the motor,**
- **If you don't use aluminum sheets, the motor will never work.**
- **It is necessary using a drum (cylinder), because the adjustment of the rear magnet's elevation are very precise, to prevent the equilibrium of magnetic forces. You need to move those magnets with your hands up or down every 45 degrees of rotation until to get 1 degree more getting repulsive force of the next magnet and following with the next one,**
- **The magnets in the drum need to be:**
- **The front ones fixed, the rear ones mobile with adjustment and method to fix in the drum when you get constant rotation, I used one bolt and nut in each magnet.**
- **The aluminum sheets are one of the most important part of the motor, they are not only the switch ON and OFF, they prevent the equilibrium of magnetic forces. The adjustment of rear aluminum sheets versus the front ones is very precise. When you move out to the back the front ones the rear sheets are moving to the front 1 degree less then the front ones. When I have built the motor, I have used different types of thread in the front axle versus the rear one who support the front and rear aluminum sheets. This axle you turn clockwise using your finger according the diagram.**
- **I have got 600 RPM with ferrite magnets, 3000 RPM with NIB magnets and up to 300 Watts/hour free electricity output with no electrical input....**
- **Following my instructions you will get every thing done....." (Nelson Camus)**

Nelson Camus has said to me that he has built himself his own model in 1993 and that he has succeed to obtain a self-running motor without external power during a period of 6 months !! Today, unfortunately, the box containing the Nelson's model has been lost/stolen during his latest move to his new adress....

Tests Reports on the QMM Mk10 by Jean-louis Naudin

If you need more informations or if you have any suggestions send me your **Feedback**

 Email : **JNaudin509@aol.com**